

# ICC-ES Evaluation Report

**ESR-2424**

Reissued March 1, 2010

*This report is subject to re-examination in two years.*[www.icc-es.org](http://www.icc-es.org) | (800) 423-6587 | (562) 699-0543

A Subsidiary of the International Code Council®

**DIVISION: 02—SITE CONSTRUCTION****Section: 02450—Foundation and Load-Bearing Elements****REPORT HOLDER:**

**CLIFFCORP INC.**  
28 AMBERWOOD LANE  
FREDERICTON, NEW BRUNSWICK E3C 1L7  
CANADA  
(506) 452-8919  
[www.foottube.com](http://www.foottube.com)  
[concrete@foottube.com](mailto:concrete@foottube.com)

**EVALUATION SUBJECT****6" FOOTING TUBE, 8" FOOTING TUBE, AND 10/12"  
FOOTING TUBE CONCRETE PIER FORMS, AND FTB30  
BASE PIER****1.0 EVALUATION SCOPE****Compliance with the following codes:**

- 2006 *International Building Code*® (IBC)
- 2006 *International Residential Code*®
- BOCA® *National Building Code/1999* (BNBC)

**Property evaluated**

Structural

**2.0 USES**

The 6" Footing Tube, 8" Footing Tube and 10/12" Footing Tube concrete pier forms are used for stay-in-place formwork for a combination concrete pier and concrete footings. The FTB30 base pier form is used in combination with the 8" Footing Tube or the 10/12" Footing Tube forms to create additional load-bearing area for the concrete piers.

**3.0 DESCRIPTION****3.1 6" Footing Tube, 8" Footing Tube and 10/12"  
Footing Tube:**

The 6" Footing Tube, 8" Footing Tube and 10/12" Footing Tube concrete pier forms are hollow plastic tapered tubes with a flanged base. The forms are manufactured from recycled polyethylene plastic. See Figure 1 for product dimensions and details.

**3.2 FTB30:**

The FTB30 is a base pier form manufactured from recycled polyethylene plastic. See Figure 2 for product dimensions and details.

**3.3 Concrete:**

The concrete used with the forms must be normal-weight concrete complying with the applicable code, with <sup>3</sup>/<sub>4</sub>-inch (19 mm) maximum size aggregate and a 3-inch (76.2 mm) slump.

**3.4 Reinforcement:**

When applicable, reinforcement must be designed in accordance with the foundation design. See Section 4.1.

**4.0 DESIGN AND INSTALLATION****4.1 Design:**

The design of the concrete footings and piers formed by the forms, and attachment of the structure to the concrete pier, are outside the scope of this report and must be in accordance with the applicable code. Load-bearing capacity of the concrete foundation must be based on end bearing.

**4.2 Installation:**

**4.2.1 6" Footing Tube, 8" Footing Tube and 10/12" Footing Tube:** The forms used as forms for a combination concrete pier and footing must be placed directly on undisturbed soil or compacted fill in accordance with the applicable code. The bottom of the forms must be installed below the frost line in accordance with the applicable code. Backfill must be placed over the footing form to a minimum depth of 3 feet (914.4 mm) from the bottom of the footing form (and not to be higher than the top of the concrete pier) and compacted, prior to concrete placement. Any additional backfilling must be completed after the concrete has been placed. The top of the form must be removed from the forms with knife or saw, along the pregrooved scribe lines. Concrete and steel reinforcing bars, when used, are placed in accordance with the applicable code. In addition, the concrete must be placed in lifts of 12 inches (305 mm), with the concrete being consolidated after each lift in accordance with the applicable code.

**4.2.2 FTB30:** The FTB30 is placed directly on undisturbed soil or compacted fill as described in Section 4.2.1. The 8" or 10/12" Footing Tube forms are placed on top of the FTB30 and leveled. The footing tube is then secured to the FTB30 with four No. 8 wood screws, screwed down through the bottom flange of the tube into the FTB30 at equal distances around the tube. Backfill and concrete are placed as described in Section 4.2.1.

**5.0 CONDITIONS OF USE**

The 6" Footing Tube, 8" Footing Tube, 10/12" Footing Tube and FTB30 described in this report comply with, or are suitable alternatives to what is specified in, those codes listed in Section 1.0 of this report, subject to the following conditions:

- 5.1 The footing form system is installed in accordance with this evaluation report and the manufacturer's published installation instructions. In the event of a conflict between the manufacturer's published installation instructions and this report, this report governs.
- 5.2 The concrete footing systems described in this report must be designed in accordance with the applicable code.
- 5.3 Engineering calculations and drawings demonstrating compliance with this report must be provided to the code official. The calculations and drawings must be prepared by a registered design professional where required by the statutes of the jurisdiction in which the project is to be constructed.

5.4 Special inspection must be provided in accordance with IBC Section 1704 and/or Section 1705 of the NBC, as applicable, for all installations.

**6.0 EVIDENCE SUBMITTED**

Data in accordance with the ICC-ES Acceptance Criteria for Plastic Footing Form Systems (AC292), dated February 2005 (editorially revised February 2008).

**7.0 IDENTIFICATION**

Each Footing Tube and base pier covered by this report must be labeled with the manufacturer's name (The Footing Tube), address and telephone number; the product trade name; and the evaluation report number (ESR-2424).

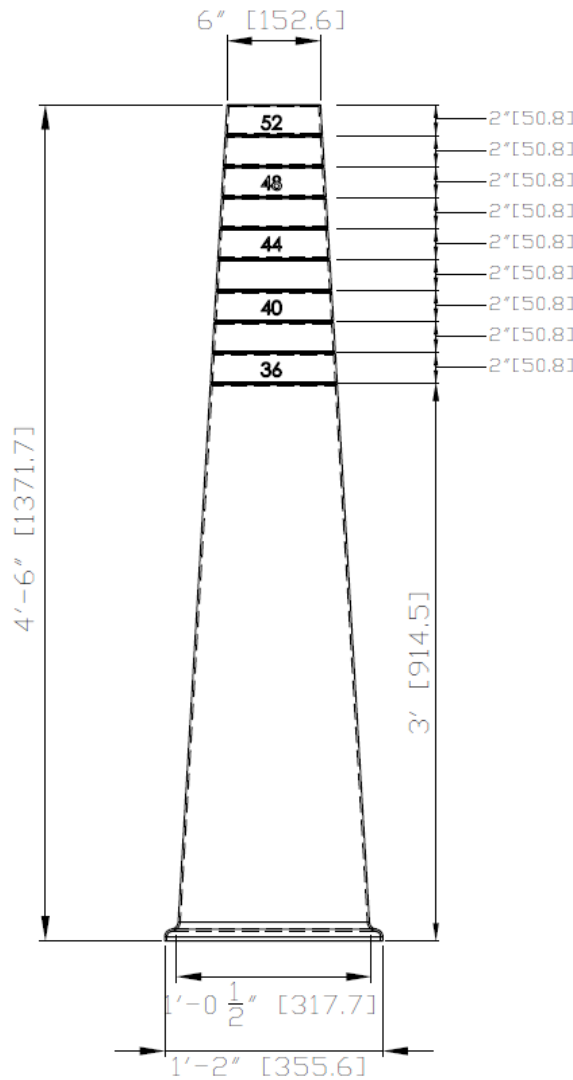

**FIGURE 1—FOOTING TUBE**

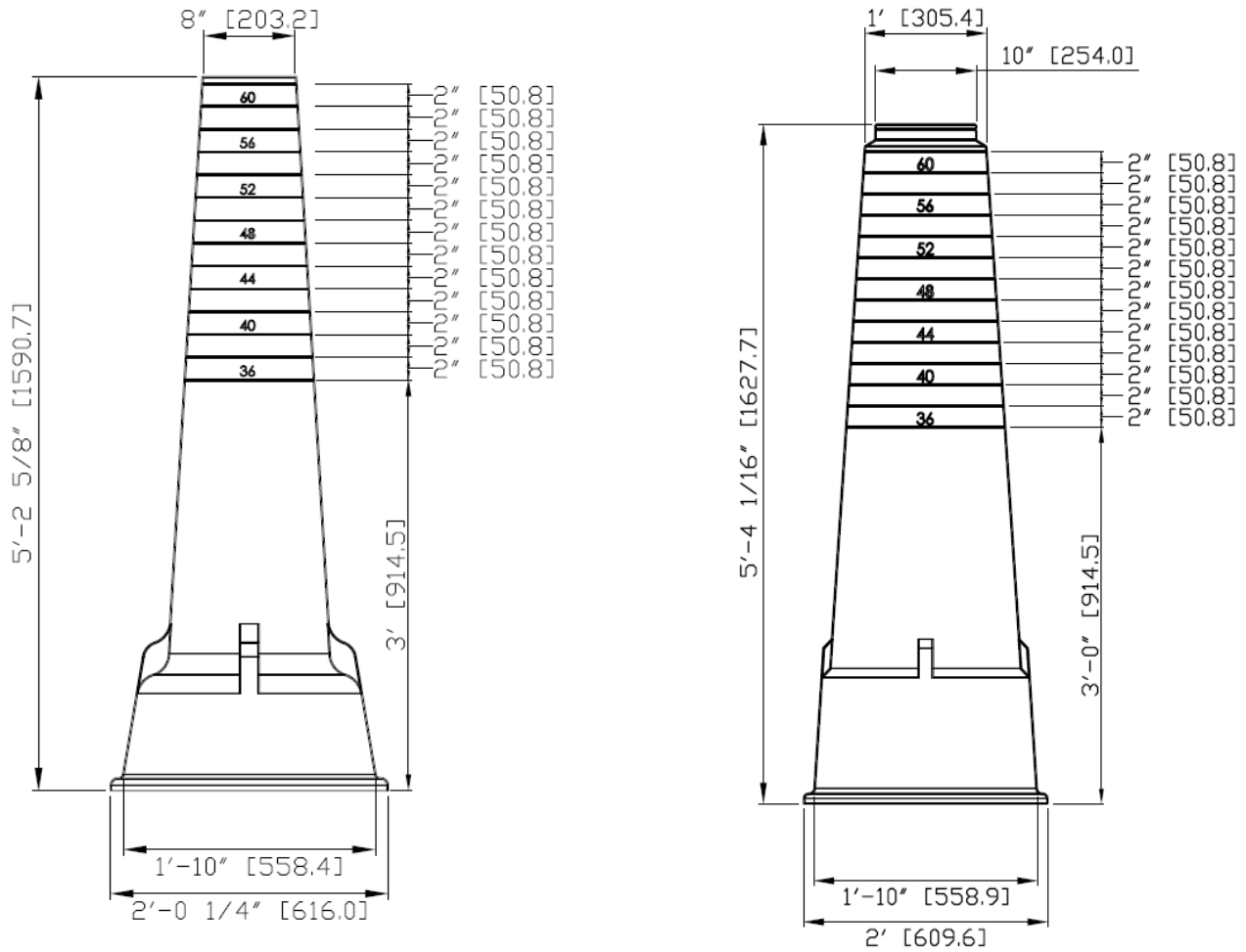

FIGURE 1—FOOTING TUBE (Continued)

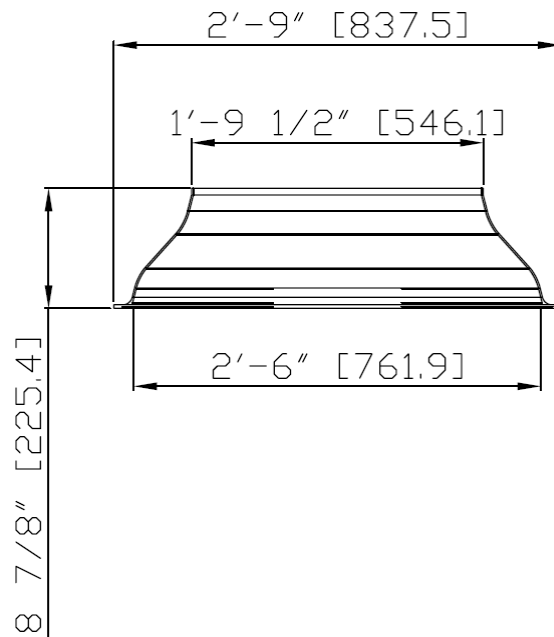

FIGURE 2—FTB 30 BASE PIER